



Freightliner (Mid-roof style cab)

Part number **7845**

ROADMASTER your source for quality truck accessories

Page 1 of 2

Important! Read entire 2 page instructions before beginning

Contents

Item	Qty	Description	Size
1	2	Visor body halves	18" x 35"
2	4	Visor brackets	11-3/4" x 1-7/8"
3	20	Truss head machine screws	1/4-20 x 1/2"
4	12	Washers	1/4-20
5	12	Lock nuts	1/4-20

Items you will need

Safety glasses
Silicone or Loctite
7/16" Box wrench
Phillips head screw driver

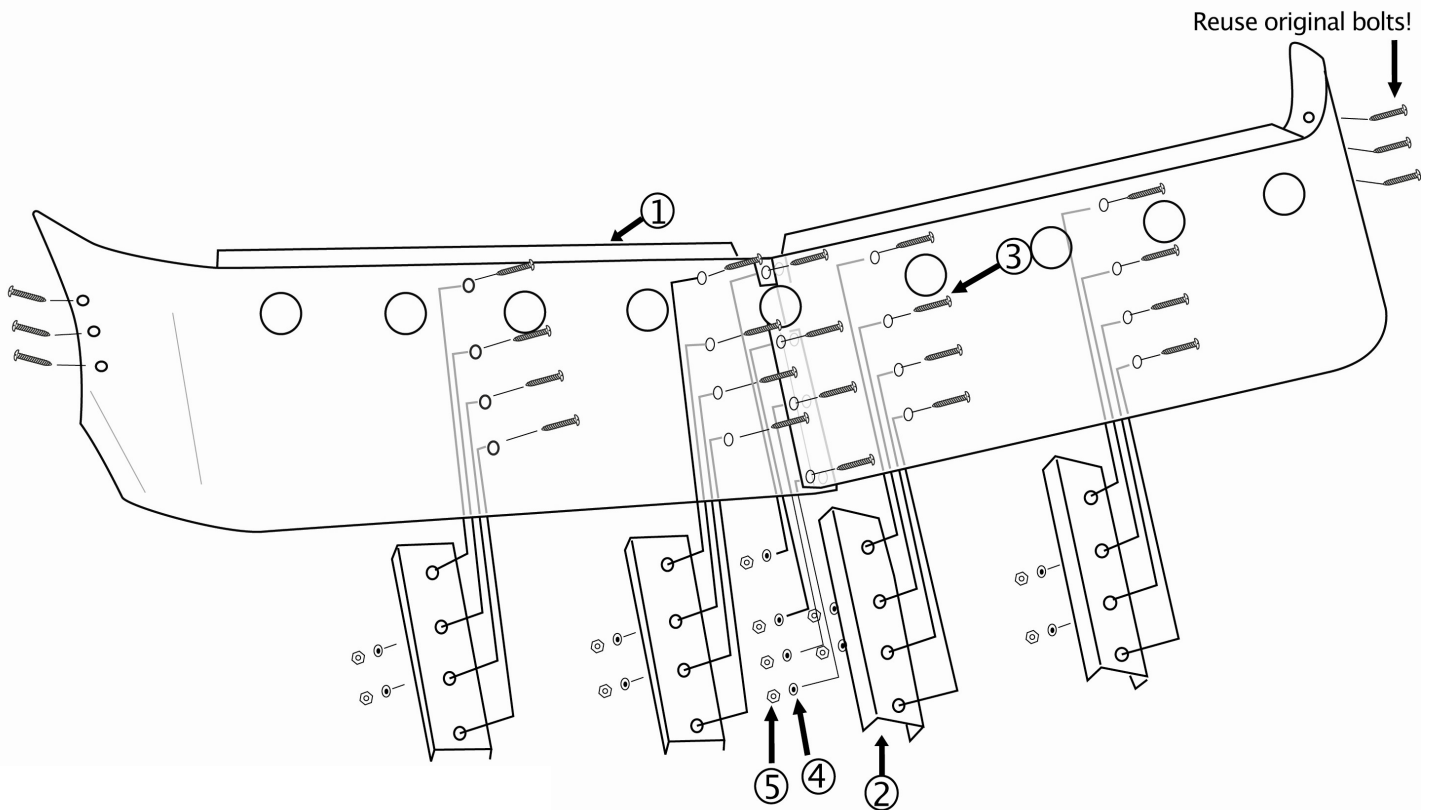

13813 S. Main Street, Los Angeles CA 90061 " (310) 767.5900 " fax (310) 767.5901

www.thinkroadmaster.com



Important! Read entire 2 page instructions before beginning

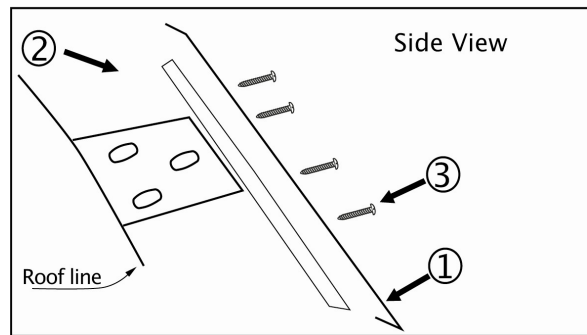

Steps:

1. Remove your current visor:
 - a. Note: You will need to reuse the bolts which go into the side of the cab at the ends of the visor.
2. Install the drivers side portion (Item 1) of the visor first.
 - a. Screw in a couple of turns the "side of cab bolts" through the holes in the end of the visor.
 - b. Start the machine screws into the outside bracket to temporarily hold it in position.
3. Repeat Step 6 with the passenger side.
4. Where the visors join together, screw in the top and bottom machine screws until almost tight.
5. Align the visor by snugly tightening one of the screws in each mounting bracket. Start from the outside of the cab and work toward the middle, one bolt per bracket at a time.
6. Remove the PVC coating from the visor.
7. Once the visor is in alignment, back out the top and bottom screws and apply silicon or Loctite then tighten all screws.
8. Install lights.