



Peterbilt 379 Drop Visor

Part number **7810**

ROADMASTER your source for quality truck accessories

Page 1 of 2

Important! Read entire 2 page instructions before beginning

Contents

Item	Qty	Description	Size
1	2	Visor body halves	14" x 35"
2D	2	Outer visor bracket driver side	11-3/4" x 1-7/8"
2P	2	Outer visor bracket passenger side	11-3/4" x 1-7/8"
3	17	Truss head machine screws	1/4-20 x 1/2"
4	33	Washers	1/4-20
5	12	Rubber welnuts	1/4-20
6	12	Hex head bolt	1/4-20 x 3/4"
7	1	Center visor bracket	13-1/2" x 7" x 3"
8	17	Lock Nut	1/4-20

Items you will need

Safety glasses
Grinder
Silicone or Loctite
Masking tape
1/2" Drill bit
10mm Metric wrench
7/16" Wrench
Phillips head screw drive
Window cleaner and paper towels

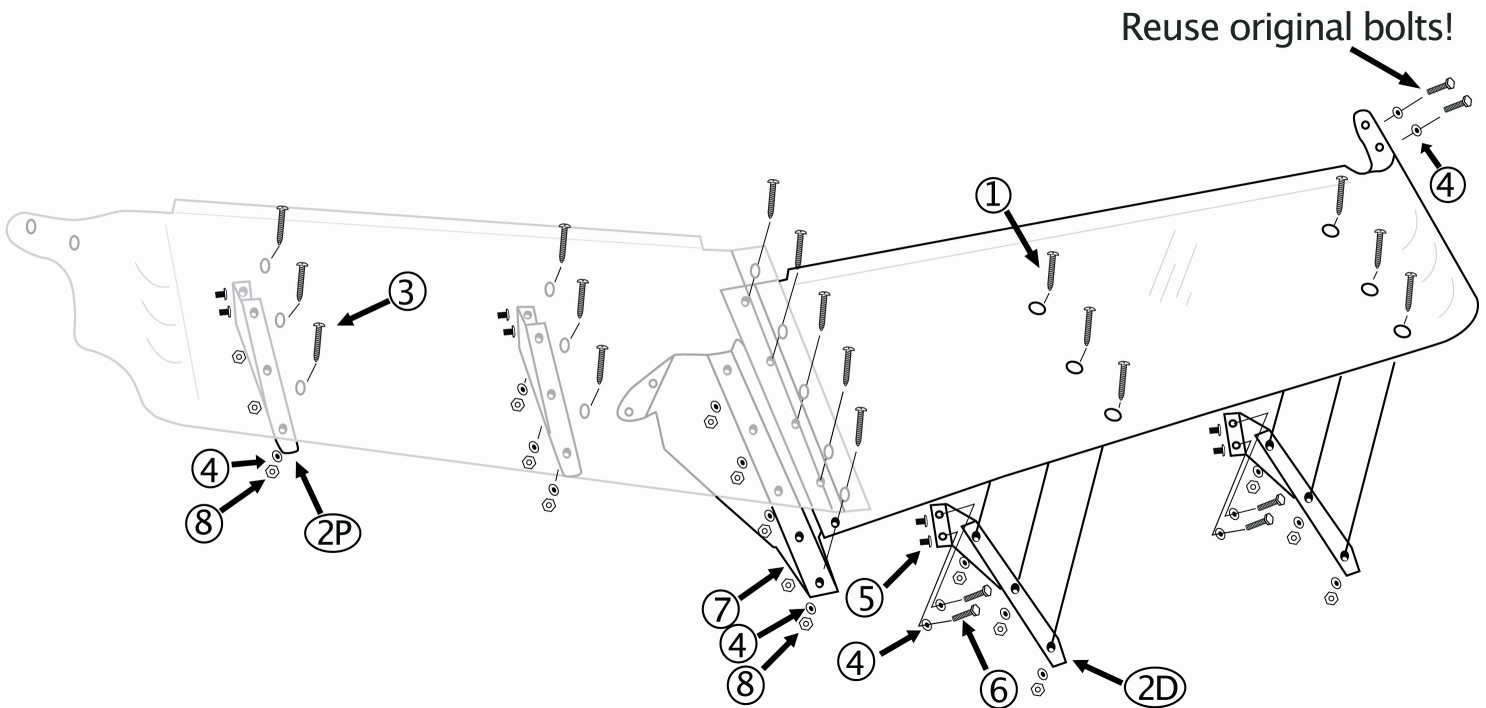

13813 S. Main Street, Los Angeles CA 90061 " (310) 767.5900 " fax (310) 767.5901

www.thinkroadmaster.com



Peterbilt 379 Drop Visor

Part number **7810**

ROADMASTER your source for quality truck accessories

Page 2 of 2

Important! Read entire 2 page instructions before beginning

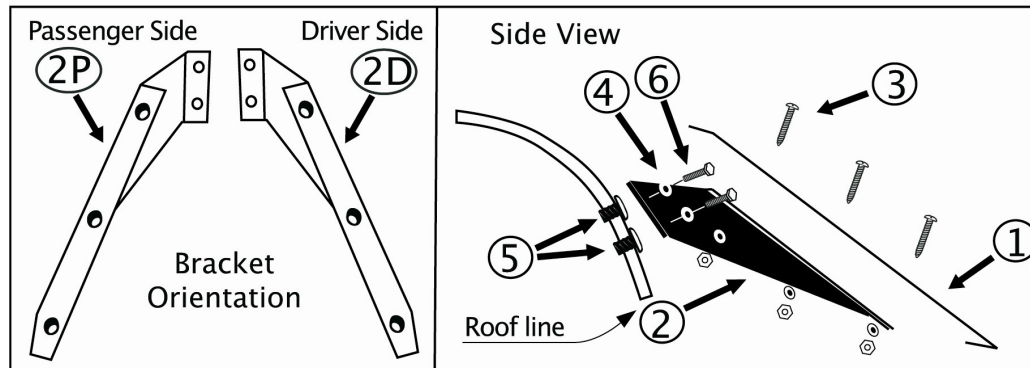

Steps:

1. Remove your current visor:
Note: You will need to reuse the bolts which go into the side of the cab at the ends of the visor.
2. Grind off the heads of the Huck bolts.
Hold the existing brackets in place and take your time grinding Huck heads. If you grind too fast or hard it will melt the paint around the head. It is recommended that you only grind a little bit at a time.
3. Drill out the "Huck" holes with a 1/2" diameter drill bit.
Drilling requires you to have a "drill-stop", if you do not have one wrap tape around the drill bit approximately one inch from the tip of the bit, this will prevent "Breaking through" and damaging the interior headliner.
4. Press the well nuts into the 1/2" holes. (See Side View illustration).
5. Install the mounting bracket per illustration. Once you feel the bolt "bottom out" STOP TIGHTENING.
6. Install the drivers side portion (Item 1) of the visor first.
Screw in a couple of turns the "side of cab bolts" through the holes in the end of the visor.
Start the machine screws into the outside bracket to temporarily hold it in position.
7. Repeat Step 6 with the passenger side.
8. Where the visors join together, screw in the top and bottom machine screws until finger-tight.
9. Align the visor by snugly tightening one of the truss head machine screws in each mounting bracket. Start from the outside of the cab and work toward the middle, one bolt per bracket at a time.
10. Remove the PVC coating from the visor.
11. Once the visor is in alignment, tighten the machine screws with the Nylon lock nuts.
12. Tighten all remaining bolts and machine screws. We recommend that you use silicone or Loctite® on each of the screws to prevent loosening from over the road use.
13. Wipe away fingerprints with window cleaner.



13813 S. Main Street, Los Angeles CA 90061 " (310) 767.5900 " fax (310) 767.5901

www.thinkroadmaster.com